

Installation Guide For NVT28U, NVT35U, NVT70P, NVT70PE

Important.

- Do not have external power connected when connecting to the computer via the USB-Mini cable.
(The screen will power from the USB).
- Use an unique DEVICE NUMBER that has not already been used.
It is preferable to make the screen as MAC 1 on the MSTP network.
- Do not use Animated Gif files for animation.
(The screens do not support animated gif files but you can use 3 pictures with the animation template).
- There is a limit of 10K per page.
- Check the correct power supply is being used for the screen.

TIPS.

Make one project per screen within HMikit software.
You can use any existing graphics (some adjustments may be needed) or Airtek graphics.
You can copy pages (ie: 000001.dsp) to other projects by using windows "Copy & Paste".

Parts Required:

1. Airtek HMikit software.
2. NVT screen.
3. USB-Mini cable (Not supplied).



Getting Started.

1. Install HMIkit software.

Minimum requirements are Windows XP upward to Windows 10.

Default

User : Admin

Password : pass

2. Create your NEW project.

Restart HMIkit software after creating the NEW project.

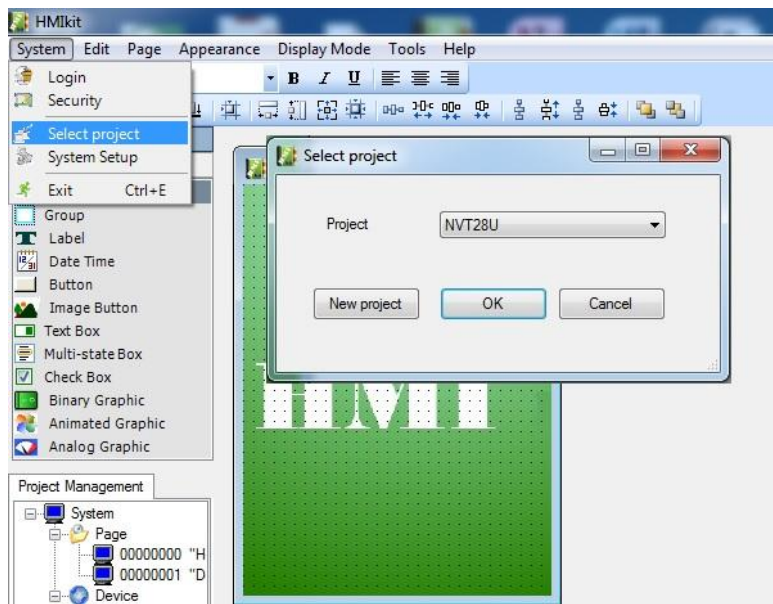

3. Set Up Security Levels if required.

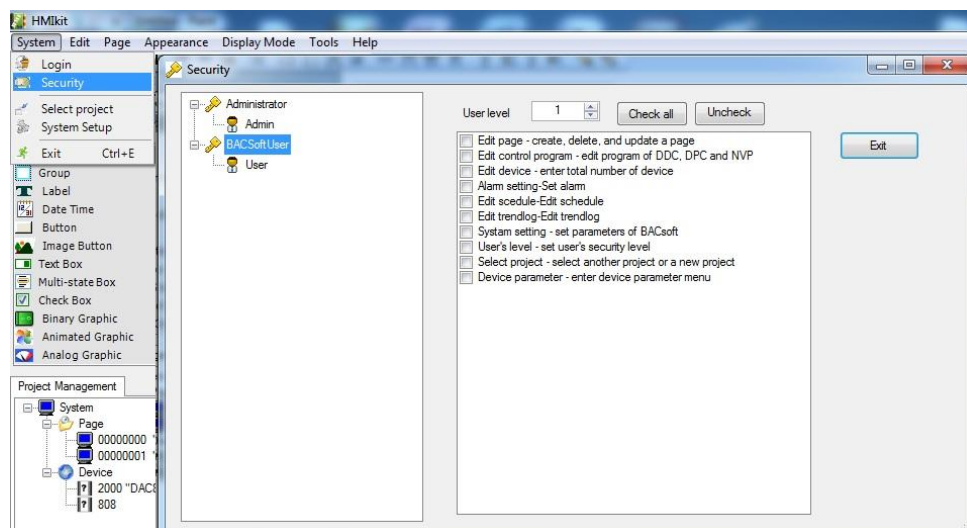

SCREEN CALIBRATION

If the screen needs calibrating please follow the following instructions:

1. Power down the screen.
2. Hold down the Number 3 key (III) while powering backup.
3. A calibration message should appear on the screen. Touch the message.
4. 4 Dots will appear, touch each one starting from the top left dot.
5. Repeat once more then it is complete, touch the screen anywhere and it should return to the home page.

NVT28U & NVT28H

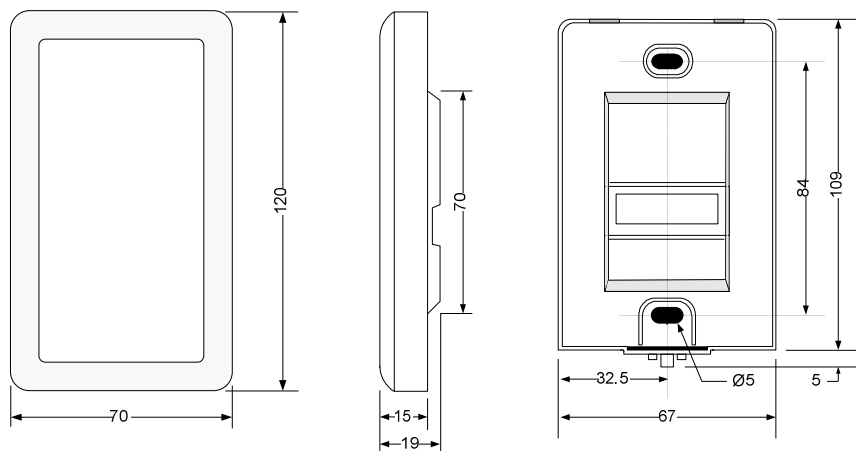

NOTE:

USB cable connection is accessible from behind the plastic base plate. The base plate snaps into the back of the main screen.

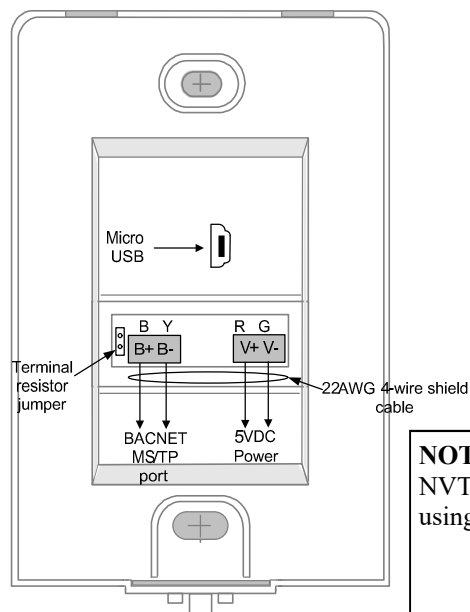

NOTE:

NVT28*** screens can be powered using 5VDC –12VDC.

HORIZONTAL Mode (NVT28H)

Please order the screen as a NVT28H for horizontal mode.
If you have a NVT28U and want to use it in Horizontal mode, it is possible to update the firmware.

NVT35U

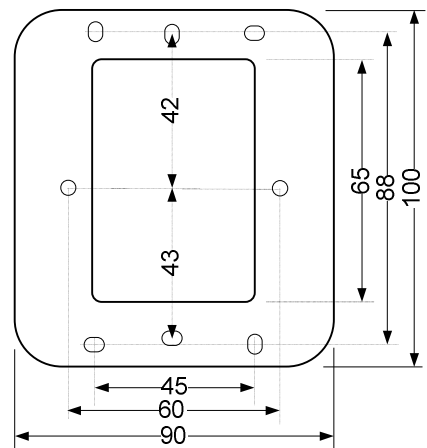
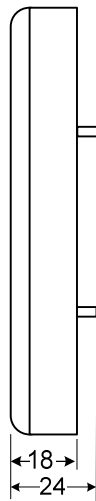
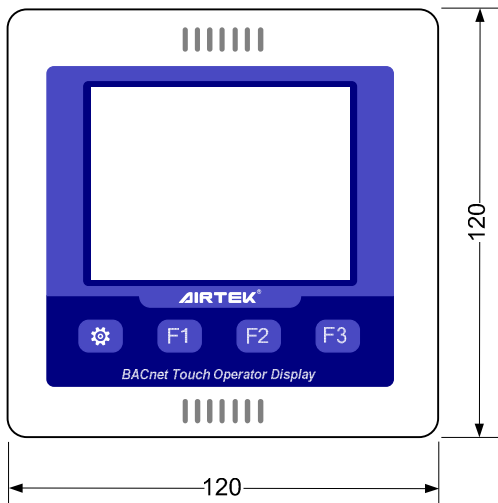
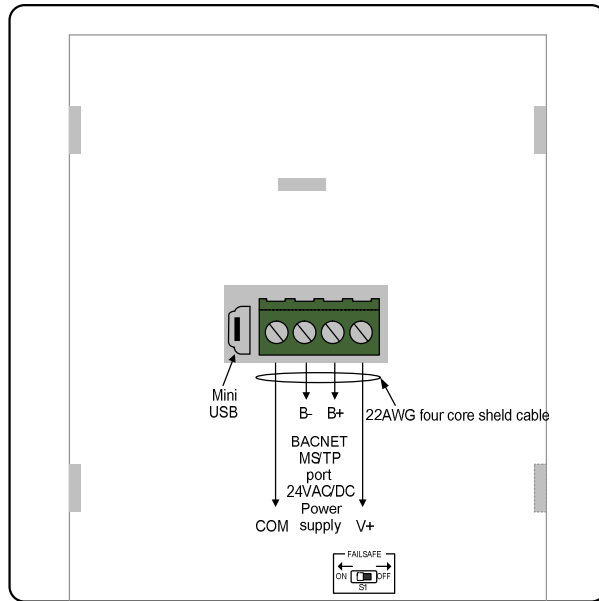

NVT70P & NVT70PE

