

PNEUMAPULSE™ PNEUMATIC CONTROL INTERFACE INSTALLATION AND OPERATING INSTRUCTIONS

DESCRIPTION

The Solidyne PneumaPulse, used in conjunction with the Micromizer III electronic controller is designed to fill a need in the building automation marketplace by making available a pneumatic control device that has a simple installation and start-up procedure, is affordable for new or existing buildings, provides electronic sensing, electronic control and pneumatic actuation. With this product, direct digital control of pneumatic controlled devices is attained for a variety of small or large control applications. The PneumaPulse is designed to provide a pneumatic signal output that is capable of positioning pneumatic valves, dampers, or actuators for a controlled medium.

SPECIFICATIONS:

Model number: 00-3255

Action type: Proportional Direct or Reverse Acting

Set Point Range: -24 to 230 units*

Throttling Range: 2 to 18 units*

Adjustments: None

Main Air Pressure: 20 PSIG Nominal
30 PSIG Maximum

Output Range: 0 to 20 PSIG

Output Capacity: 1600 SCIM

Air Consumption: 9.0 SCIM

Calibration Point: Factory Set at 7.5 PSI @ continuous 3 sec. ON/3 sec. OFF duty cycle.

*units dependent on programming of MICROMIZER III controller.

Calibration Tolerance: 0.2 PSI

Ambient Temperature: 0°F to 140°F Operating

Power Input: 24 VDC (± 5 VDC)

Power Consumption: .65 Watts @ 24 VDC

Dimensions: 6 1/2" x 4 1/2" x 2 1/4"

CAUTION

The air supply to the PneumaPulse must be dry and filtered to 10 Microns.

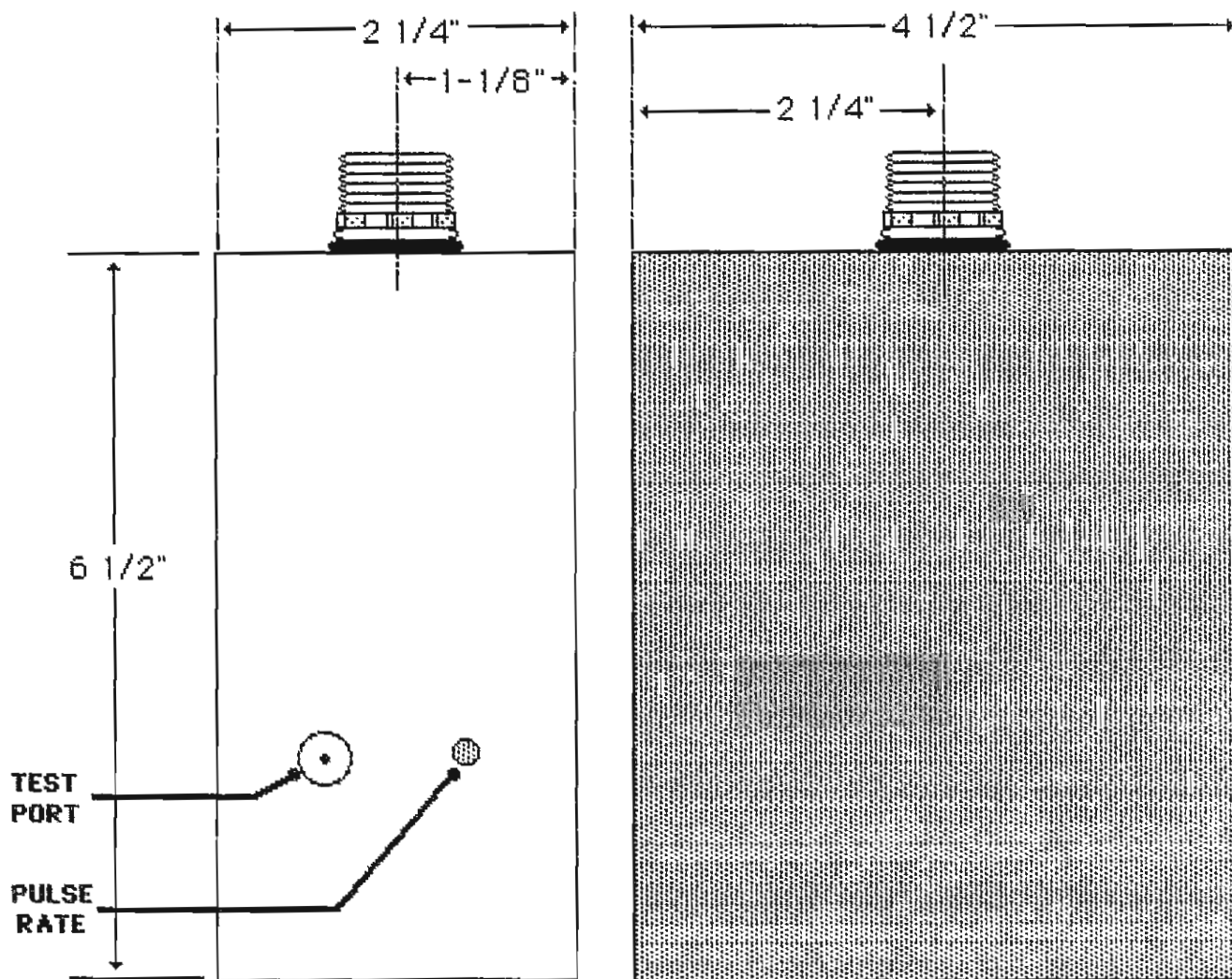

Figure 1. Pneuma-Pulse Dimensions.

PACKAGING

The PneumaPulse is available in a modular form. Dimensions are standardized at 5 1/2" H x 5 1/2" D x 3" W, and a panel or track type of mounting is recommended for installation. Each device has an LED display for pulse input indication, and a needle-insert pneumatic test port for branch output monitoring. A 1/2" male fitting is made available for mounting, and signal connectors exit the module from the fitting opening for external connections. No internal connections are required. (See Figure 1.)

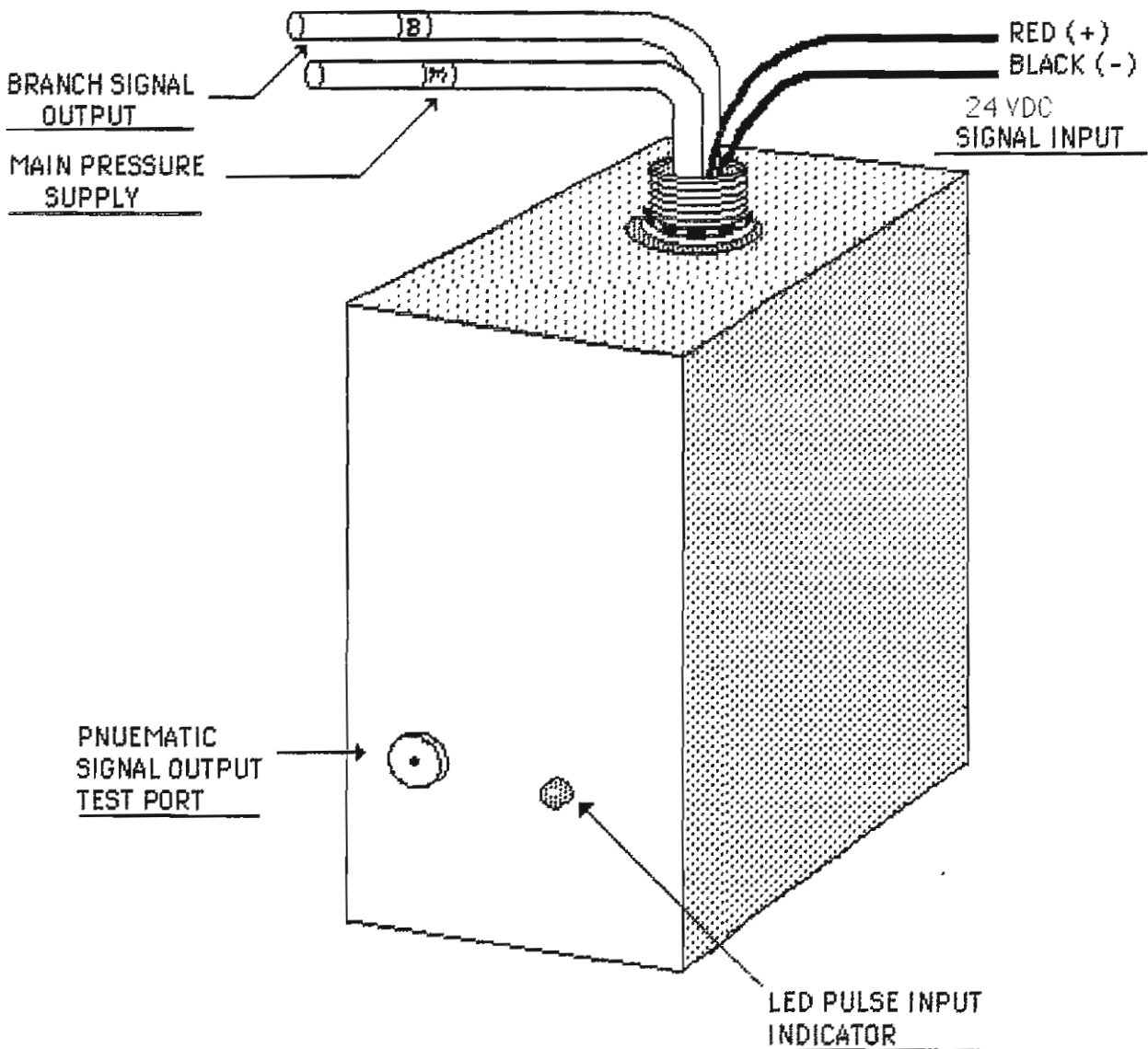

Figure 2. Pneuma-Pulse connections.

CONNECTIONS

The module is furnished with two (2) #18 gauge wires for signal input to the module, and two (2) standard 1/4" pneumatic tubes, one for main pressure supply (labeled "M"), and the other is for the branch, or signal output (labeled "B"). Air consumption is 9.0 SCIMs.

A separate DC power supply must be used to provide power to the PneumaPulse as shown in figure 4. The RED wire (+) is switched through the controller relay while the BLACK wire (-) is connected directly to the common (-) of the power supply. The power supply must be able to supply at least 1 VA per PneumaPulse.

CALIBRATION DATA

Due to the design of the PneumaPulse, there is no requirement for field calibrations as received from the factory. Signal output at rest (or set point satisfied condition) is factory calibrated at 7.5 PSIG. The output control range is optionally adjusted with a programmable throttling range. All of the operating definitions of Direct/Reverse acting, throttling range, and set point range are programmed functions at the controller from the keypad or through the Remote Communications Software from an IBM PC or Apple computer.

OPERATION

The PneumaPulse provides an output signal that is in direct or reverse proportion to its assigned input. The analog inputs to the Micromizer are solid state devices measuring a controlled variable; ie, air, water, temperature, pressure, pulse, etc., within a pre-determined analog range. The input rate of change can then vary an assigned output pulse rate to the PneumaPulse. Any of the analog inputs is programmable to act as a controlled variable to control any or all of the output points. Total input sensor capacity is 16 inputs. The total PneumaPulse type outputs can be up to all 32 of the output points

Depending on the required sequence of operation, the PneumaPulse will proportionally vary its control signal output from 0 to 20 PSIG according to the assigned analog high and low limits of the input, or as determined by the given duty cycle rates. The output signal can also be designed to have ramp-up features, or can be a discrete signal from multiple inputs, or can be from values based on calculations performed by the Micromizer.

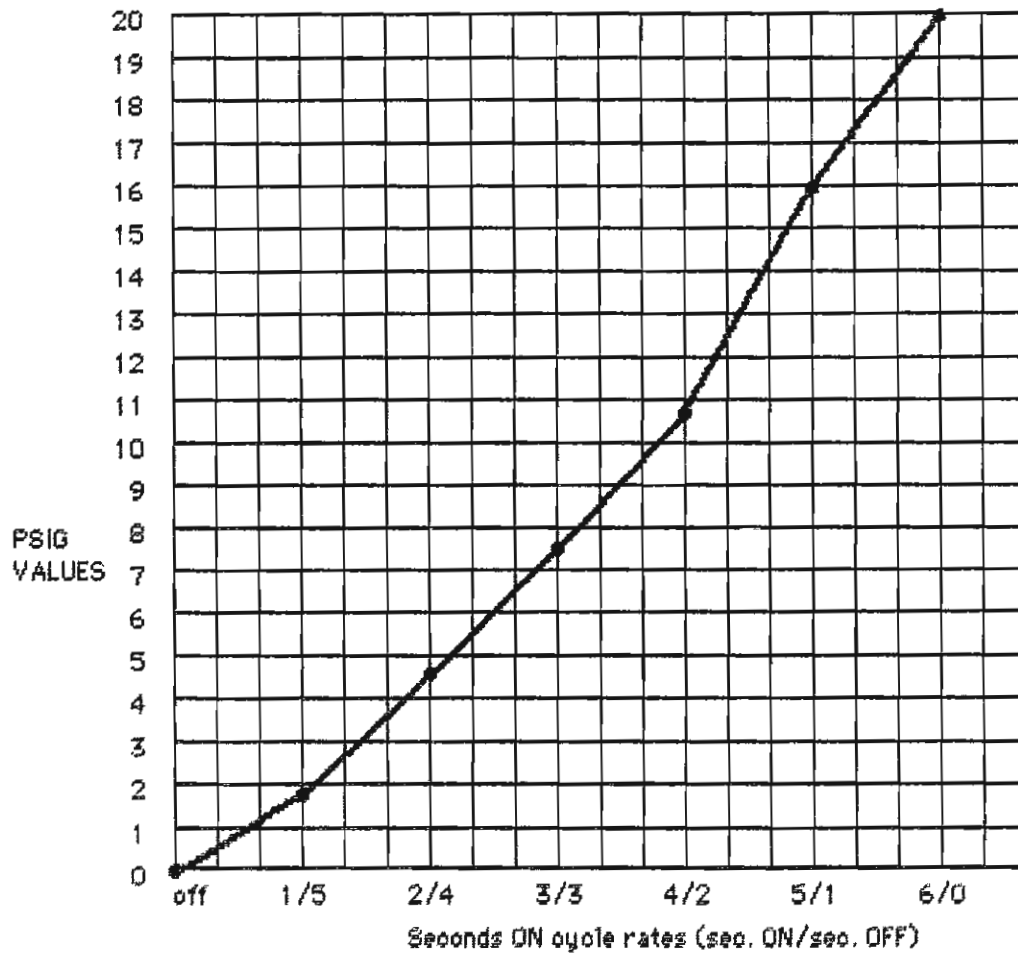

FIGURE 3. GRAPH OF CYCLE RATES VS. OUTPUT

The output signal from the Micromizer III into the PneumaPulse is a continuous seconds-resolution duty cycle pulse rate which will vary, maintain, increase, or decrease the pneumatic output signal. This type of output signal from the Micromizer can be loosely defined as a pulse width modulation signal which will control the PneumaPulse to develop a stable proportional signal output. The circuitry within the PneumaPulse can respond to minor pulse rate changes, and convert them into positive air signals with linear control accuracy. (See Figure 3.)

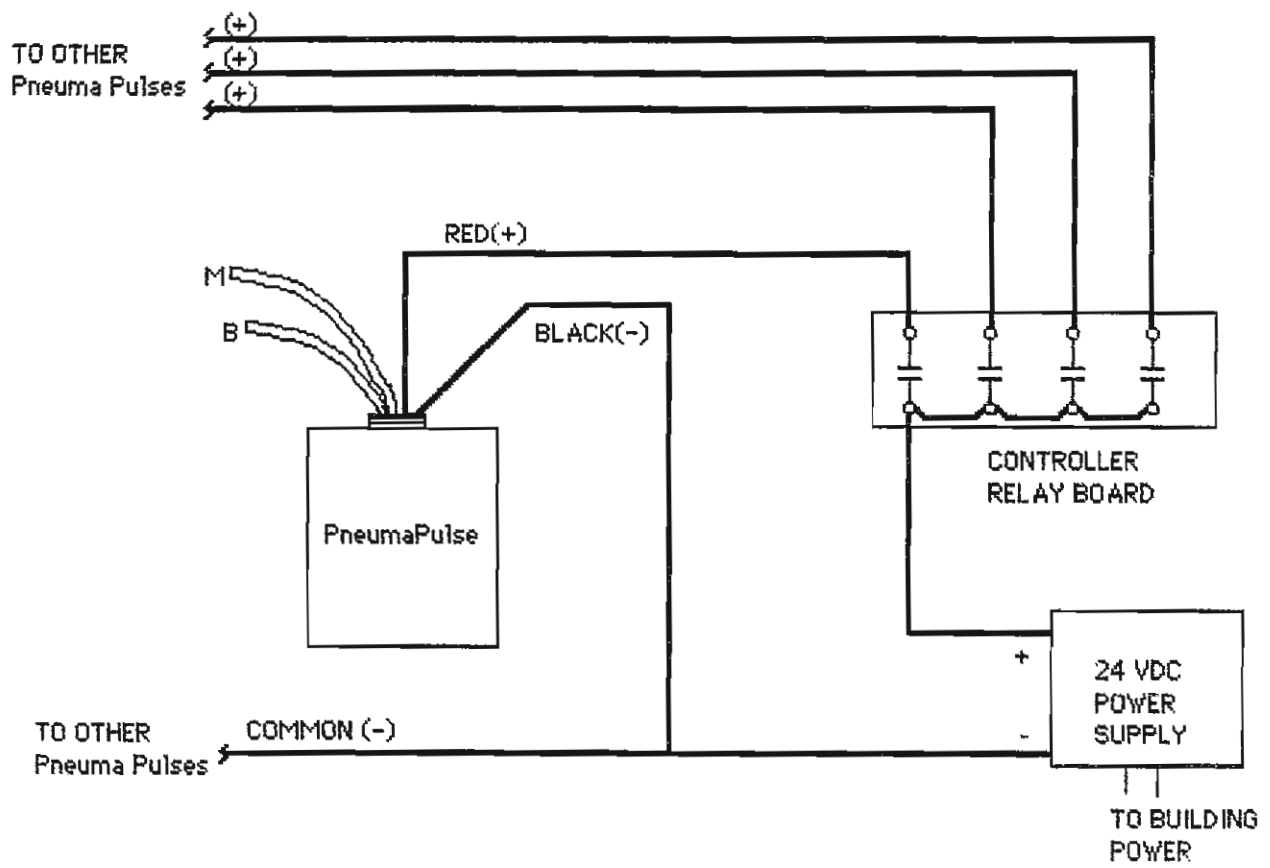

Figure 4 Typical Wiring Diagram