



**WTS-DB-P Digital Room Temperature Sensor**

The WTS family of Wall Temperature Sensors are designed to be used with the M2 family of Solidyne controllers. They are designed with a rugged anodized aluminum housing and a unique one screw attachment to it's base plate.

The WTS-DB-P is a digital wall mounted room temperature sensor with multiple modes of operation. It uses LED's to display room temperature along with room setpoint and zone override. It also has a built in light sensor which can be enabled or disabled. The WTS-DB-P wires to the M2 family of controllers via CAT-5 cabling and does not have options for hard wiring.

**Specifications**

- Input Power:** Supplied by M2 controller
- Temperature Input:** 10k Thermistor (Type III)
- Operating Temperature:** +23°F to +150°F (-5°C to +66°C)
- Storage Temperature:** -40°F to +230°F (-40°C to +110°C)
- Operating Humidity:** 10 to 95 %RH non-condensing
- Storage Humidity:** 10 to 95 %RH non-condensing

**Physical Dimensions**

**WTS-DB-P Housing:**

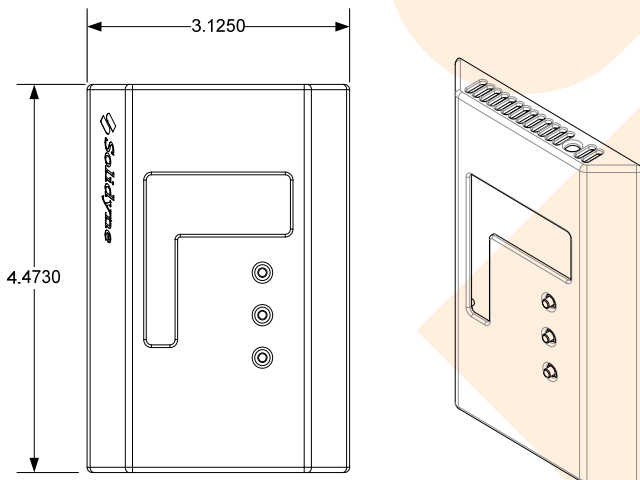

**Figure 1**

**WTS-DB-P Backplate:**

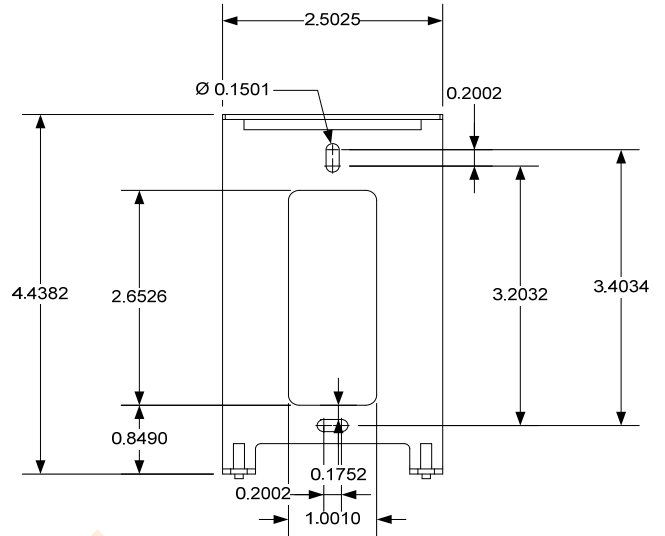

**Figure 2**

**Wiring**

The WTS-DB-P must be wired to an M2 family controller via the CAT-5 connection on the back of the device. This method uses any straight through CAT-5 cable. See figure 3 for the proper RJ-45 crimping polarity. One end of the CAT-5 cable terminates into either of the two RJ-45 female connectors on the back of the WTS-DB-P. The other end will terminate into the middle M2 RJ-45 female connector. When the WTS-DB-P is wired via this method, the temperature sensor input will automatically use Input #1 (AI1) of the M2 controller that it is attached. The zone setpoint input will automatically use Virtual Input #1 (VI1) and the light level sensor will use Virtual Input #2 (VI2) on any M2 family controller.

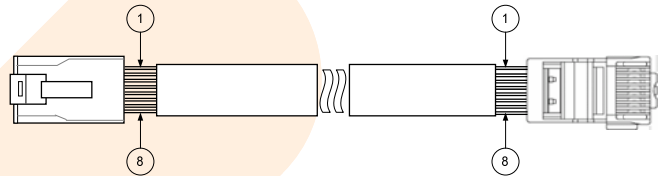

**Figure 3**

## Wiring Cont'd

### CAT-5 Wiring:

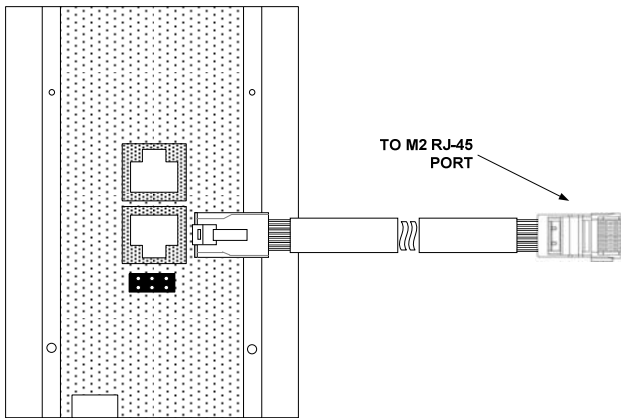

Figure 4

### CAT-5 Input Assignment:

When using the CAT-5 wiring, the M2 controllers will automatically assign its inputs to pre-defined locations:

	M2	M2V
Temperature Sensor	Input 1 (AI1)	Input 1 (Zone Temp)
Setpoint	Virtual 1 (VI1)	Virtual 1 (VI1)
Light Level Sensor	Virtual 2 (VI2)	Virtual 2 (VI2)

Table 1

### Jumper Configuration

The WTS-DB-P has 3 jumper configurations. The default jumper position is JP2 only. Other jumper configurations are reserved for future use and not applicable at this time.

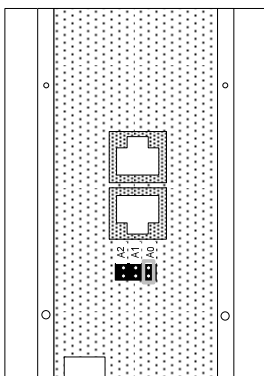

Figure 5

### M2-HH Commissioning Tool

The WTS-DB-P has a small 5 pin connector on the bottom end of the device which is used to connect the M2-HH hand held commissioning tool. Please see the 00-M2-HH documentation for

## Installation

The WTS-DB-P backplate will install easily onto any 2"x4" electrical box with the supplied 1" screws. An electrical box is not necessary for proper installation of the WTS-DB-P. The 1" screws have a flat head, if longer screws are needed, please make sure they have a flat head.

Once the backplate is installed and wiring is completed, install the WTS-DB-P sensor onto the backplate at an angle starting at the top of the sensor as shown in figure 6.

After sliding the WTS-DB-P sensor onto the top of the backplate, rotate the sensor towards the wall and secure the WTS-DB-P sensor in place by snapping it onto the bottom side of the backplate as shown in figure 7.

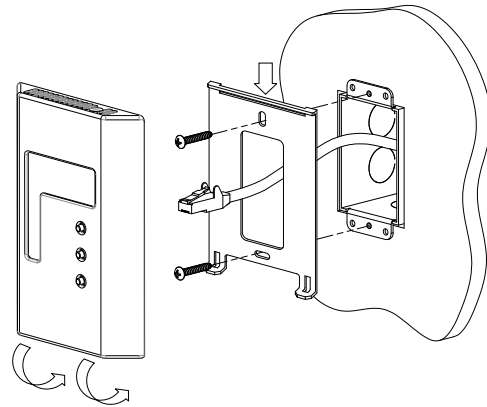

Figure 7

### Modes of Operation

The WTS-DB-P has 4 configurable modes of operation. Each of the 4 modes displays the zone temperature (either °F or °C) until a button is pushed on the unit. The different modes only change the way the setpoint is displayed/used. These different modes of operation are listed below.

#### Mode 1

This mode is the default mode for the WTS-DB-P. This gives the user an interface to view the room temperature and adjust the setpoint numerically. When the user changes the zone setpoint on the WTS-DB-P, the value will be set to Virtual Input #1. By default, the user can set the zone setpoint from 55 to 85.

#### Mode 2

This mode gives the user an interface to view the room temperature numerically, but the setpoint for the zone is displayed via the 7 LED level indicator. This 7 LED level indicator has 3 red LED's and 3 blue LED's and 1 green LED in between the 3 red and 3 blue LED's. When the user adjusts the zone setpoint the value will be set to Virtual Input #1. By default, the 7 LED level indicator has a range of +3 to -3 where 0 will be set to Virtual Input #1 when the middle green LED is set. See Figure 8 for details of the LED level indicator.

#### Mode 3

This mode eliminates the user zone setpoint all together. It does however allow the user to view the current zone temp and send a system override.

#### Mode 4

This mode is the same as Mode 3, but the LED level indicator is used to display how warm or cool the room is based on Virtual Input #1 which would be set by a device other than the WTS-DB-P (ie. ICMS graphic). With the highest red LED lit, the room is 3 or more degrees warmer than Virtual Input #1. With the lowest Blue LED lit, the room is 3 degrees cooler than Virtual Input #1

## Modes of Operation Cont'd

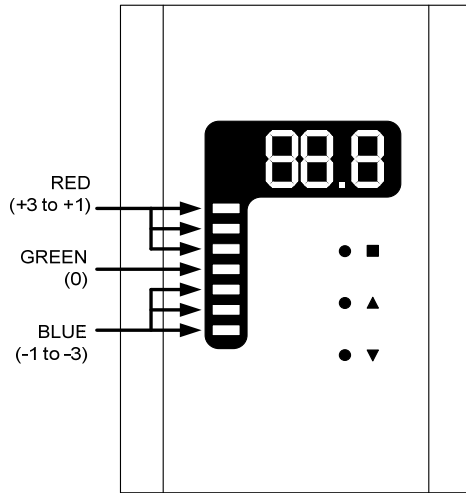

Figure 8

In Mode 2, when the highest red LED is lit, the Virtual Input #1 will be +3. Giving the system an indication that the user would like the setpoint to be 3 degrees warmer than current. Furthermore, if the green LED is lit, Virtual Input #1 would be set to a value of zero (0). And when the lowest blue LED is lit, the Virtual Input #1 would be set to -3.

## Configuring the WTS-DB-P operation with M2-HH Commissioning Tool

The M2-HH commissioning tool is used to setup and configure the 4 modes of operation for the WTS-DB-P. Please refer to the M2-HH documentation for details of connecting and using the M2-HH tool. All of the WTS-DB-P settings can be modified by select F4 on the M2-HH tool.

### Changing the Mode of Operation

To change the WTS-DB-P mode, select F4 on the M2-HH. The first item on the list is the WTS-DB-P mode. Change the mode number to whichever mode serves your application properly.

### Disable Setpoint

In any of the 4 modes, the setpoint that is written to Virtual Input #1 can be disabled by selecting the ZONE SET->VS1 setting to "N" by using the +/- key on the M2-HH.

### Disable Light Level Sensor

To disable the built in light level sensor from writing to Virtual Input #2, set the LITE SENS->VS2 setting to "N" by using the +/- key on the M2-HH.

### Disable Zone Overrides

To disable the user from triggering a zone override with the WTS-DB-P, set the ZONE OVRD ENABLE to "N" by using the +/- key on the M2-HH.

### Calibrating the Zone Temperature

The WTS-DB-P temperature sensor can be calibrated by the M2-HH if the sensor is not reading inside the desired accuracy range. After selecting F4 for WTS-DB-P Settings, select the DOWN arrow 4 times to get to the next page of the WTS-DB-P settings. The first item in the list is SENSOR ADJUST. Select OK and enter the desired amount of offset. Select OK when

## Sensor Update Rate

The rate at which the zone temperature refreshes its value on the WTS-DB-P can be adjusted between 1 and 256 seconds. In the second page of the WTS-DB-P settings, select OK on the UPDATE RATE setting and enter the desired amount of seconds. The default value is 5 seconds.

## Changing the Min and Max Setpoint Values

WTS-DB-P Mode 1 uses a numerical setpoint which can have Minimum and Maximum limits so that the user cannot change the setpoint to an extreme value. By default the Minimum setpoint value is 55 and Maximum is 85. Both of these values can be change to a more desirable limit. On the second page of the WTS-DB-P settings, select OK on either the MIN SETPOINT or MAX SETPOINT and enter the desired values that apply to your application.

## Setpoint Adjust Operation

In both Mode 1 & 2, the user can adjust the zone setpoint. The WTS-DB-P has 3 infrared emitter/receiver "buttons". These are not traditional mechanical buttons, rather they are electronic components that require the user to cover a hole in the WTS-DB-P housing which will give the same effect as pushing a mechanical button. These electronic "buttons" are used to both change the zone setpoint and set a zone override.

To change the setpoint in either Mode 1 or Mode 2, select either the up or the down arrows to adjust the setpoint on the display of the WTS-DB-P to the desired value and then select the enter button which is the top button on the WTS-DB-P indicated by an orange square.

## Zone Override Operation

In all Modes of operation of the WTS-DB-P, the user can trigger a zone override, typically used for after hours operation. The duration of this override would be configured in the ICMS software for Analog Input #1 and can be set for 1 to 255 minutes.

To trigger the zone override, the user should push the orange square button. The display will display "OR=" for 1 second and then the user can select either the up arrow to select the zone override to ON which will be displayed on the WTS-DB-P. After the override is selected to ON, select the orange square button again to confirm the override. To view the current override state, select the orange square button and the display will show either OFF (zone not currently in override) or ON (zone currently in override).

## Ordering Info:

WTS-DB-P-W: Bright White plastic version

WTS-DB-P-S: Metallic Silver plastic version

© Copyright 2015 Solidyne Corporation All rights reserved.

No part of this document may be photocopied or reproduced by any means, or translated to another language without prior written consent of Solidyne.

All specifications are nominal and may change as design improvements are introduced. Solidyne shall not be liable for damages resulting from misapplication or misuse of its products.