

## Application

The sLON-7 Controllers are programmable, interoperable, LONWORKS® based control devices.

The sLON-7 Series Controller features eight universal inputs, four analog outputs, eight digital outputs, a 5.1 volt reference, LED indication, and support for sLON-WTSx sensors. Additionally, network capability is provided through the use of a FTT-10 transceiver allowing the controller to communicate to other devices as part of a LONWORKS Free Topology Communications network. A direct connection to a sLON-ADPx Communication adapter and a PC with WPT Software Tool is necessary to download and modify applications

Typical applications include central station air handlers, VAV air handlers, fan coil units, unit ventilators, and cooling towers.

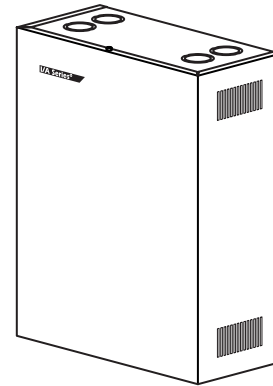

**ENC-sLON-7-W  
Wall-Mount Enclosure**

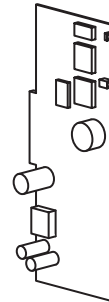

**sLON-7  
Controller Card**

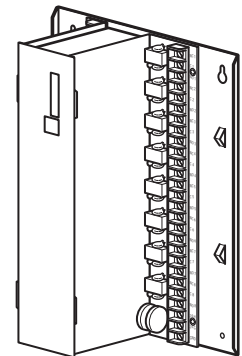

**ENC-sLON-7-P  
Panel-Mount Enclosure**

## Model Chart

Model	Description
ENC-sLON-7-W	Wall-Mount Enclosure
ENC-sLON-7-P	Panel-Mount Enclosure
sLON-7	Controller Card with Backed-up Time Clock

## Installation

### Inspection

Inspect carton for damage. If damaged, notify carrier immediately. Inspect controllers for damage. Return damaged products

### Requirements

(These items not provided)

- Installer must be a qualified, experienced technician.
- Job wiring diagrams
- Tools:
  - Drill and bits for

- panel mounting screws
  - Digital Volt-ohm meter (DVM)
  - Static protection wrist strap
- Class 1 or Class 2 power transformer supplying a nominal 24 Vac (20.4 to 30 Vac) with a minimum rating of 20 VA, 50/60 Hz per controller plus Digital Output (DO) loads (if same transformer is used). In European Community, transformer must conform to local standards.
- Terminators:
  - One sLON-T1 terminator required for free topologies
  - Two sLON-T2 terminators required for bus topologies

## Precautions



### General

---

**Warning:** Electrical shock hazard! Disconnect power before installing or removing the cover.

---

- Follow Static precautions when installing this equipment.
- Use copper conductors that are suitable for 167°F (75°C).
- Make all connections according to electrical wiring diagram, national and local electrical codes.

### Static Precautions

Static charges damage electronic components. The microprocessor and associated circuitry are extremely sensitive to static discharge. Use the following precautions when installing, servicing, or operating the system.

- Work in a static-free area.
- Discharge static electricity by touching a known, securely grounded object.
- Use a wrist strap connected to earth ground when handling the controller's printed circuit board.

### Federal Communications Commission (FCC)

This equipment has been tested and found to comply with the limits for a Class B digital device, pursuant to Part 15 of the FCC Rules. These limits are designed to provide reasonable protection against harmful interference in residential installations. This equipment generates, uses, and can radiate radio frequency energy and may cause harmful interference if not installed and used in accordance with the instructions. Even when instructions are followed, there is no guarantee that interference will not occur in a particular installation. If this equipment causes harmful interference to radio or television reception—which can be determined by turning the equipment off and on—the user is encouraged to try to correct the interference by one or more of the following measures:

- Reorient or relocate the receiving antenna.
- Increase the separation between the equipment and receiver.
- Connect the equipment to an outlet on a circuit different from that to which the receiver is connected.
- Consult the dealer or an experienced radio/television technician for help.

### Canadian Department of Communications (DOC)

This class B digital apparatus meets all requirements of the Canadian Interference-Causing Equipment Regulations.

Cet appareil numérique de la classe [B] respecte toutes les exigences du Règlement sur le matériel brouilleur du Canada.

### European Community Directives

This equipment meets all requirements of European Community Directives for Low Voltage (72/23/EEC) and Electromagnetic Compatibility (89/336/EEC).

---

**Caution:** This is a class A product. In a domestic environment this product may cause radio interference in which case the user may be required to take adequate measures.

---

## Location

These controllers are suitable for indoor use only.

---

**Caution:**

- Avoid locations where excessive moisture, corrosive fumes, vibration, or explosive vapors are present.
  - Avoid electrical noise interference. Do not install near large contactors, electrical machinery, or welding equipment.
  - Locate where ambient temperatures do not exceed 140 °F (60 °C) or fall below -40 °F (-40 °C) and relative humidity does not exceed 95% or fall below 5%, non-condensing.
- 

## Mounting

### Panel Mount Installation (ENC-sLON-7-P)

ENC-sLON-7-P uses a sheet metal mounting plate. The enclosure has four mounting holes. Mount in a vertical position as shown in Figure-1. Allow access for wiring and removal of the assembly for service.

Use the mounting holes provided.

---

**Caution:**

- Drilling holes in the controller or mounting plate voids warranty.
  - Do not drill into mounting plate or any other part of controller. Metal chips and other debris may short-circuit electronic components.
- 

1. Select mounting location.
2. Using four #8 pan head screws, mount base of controller to a panel.
3. Wire controller (See Wiring section).
4. After wiring, remove aluminum cover plate.
5. Remove protective tape from edge of card connector.
6. Install printed circuit board. (See sLON-7 Printed Circuit Board Installation.)

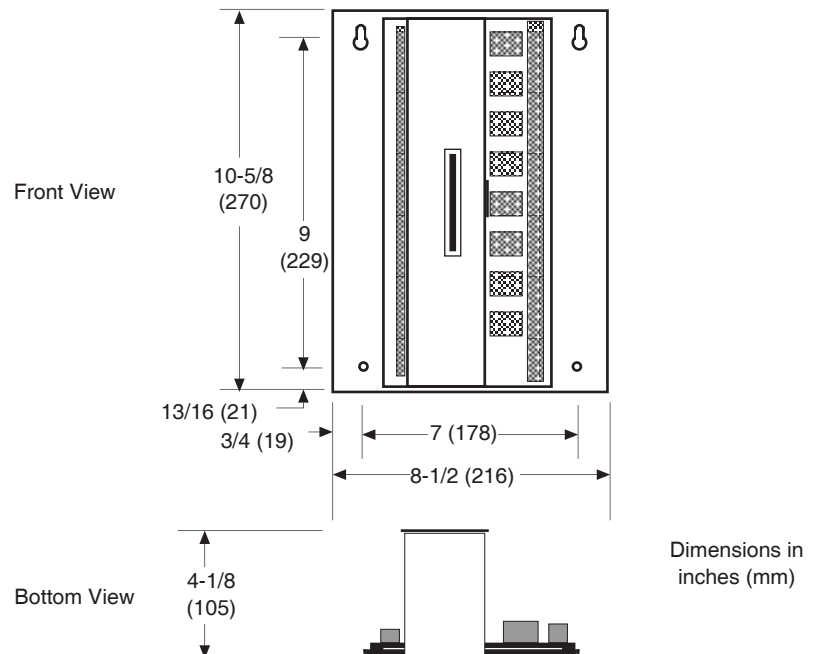

Figure-1 ENC-sLON-7-P Panel Mounting Dimensions.

### Wall Mount Installation (ENC-sLON-7-W)

ENC-sLON-7-W use a sheet metal enclosure. The enclosure has four mounting holes and eight combination knockouts (1/2" to 3/4") (see Figure-2). Mount in a vertical position and allow access for wiring and removal of the printed circuit board assembly for service.

Use the mounting holes and knockouts provided.

**Caution:**

- Drilling holes in the controller or enclosure voids the warranty.
- Do not drill into the enclosure or any other part of the controller. Metal chips and other debris may short-circuit electronic components.

1. Select mounting location.
2. Remove cover.
3. Using four #8 pan head screws, mount controller.
4. Wire controller (See Wiring section).
5. Remove protective tape from edge of card connector.
6. Install printed circuit board. (See sLON-7 Printed Circuit Board Installation.)

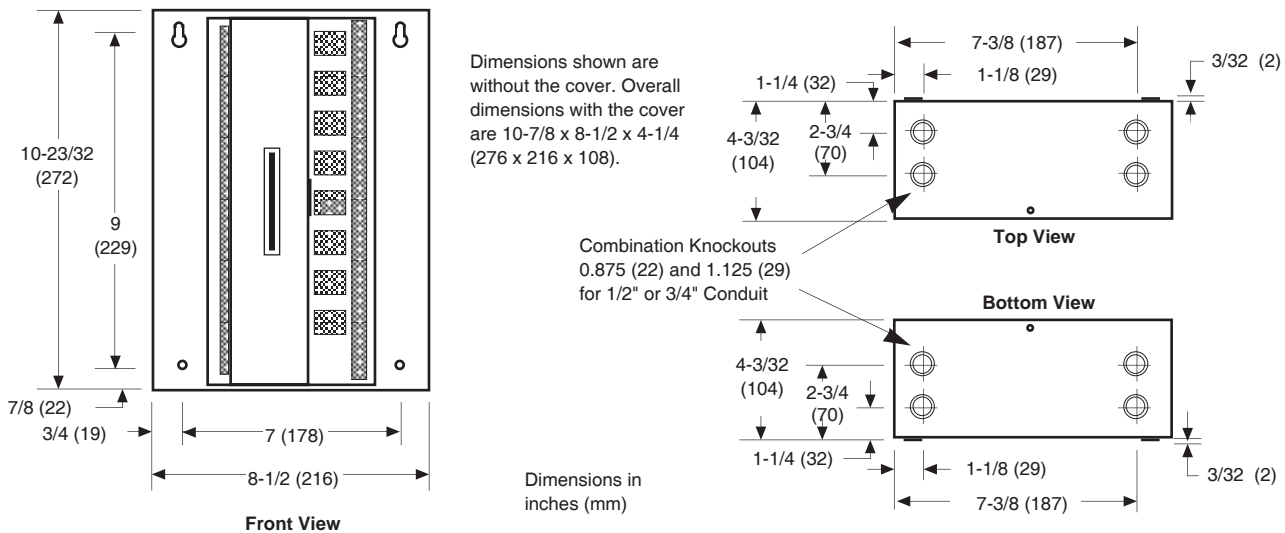

Figure-2 ENC-sLON-7-W Wall Mounting Dimensions.

## Wiring

See Figure-3 for terminal connections.

A power transformer supplying a nominal 24 Vac (20.4 to 30 Vac) with a minimum rating of 20 VA, 50/60 Hz per controller is required. The supply to the transformer must be provided with a circuit breaker or disconnect. Use class 1 wiring for the transformer wiring.

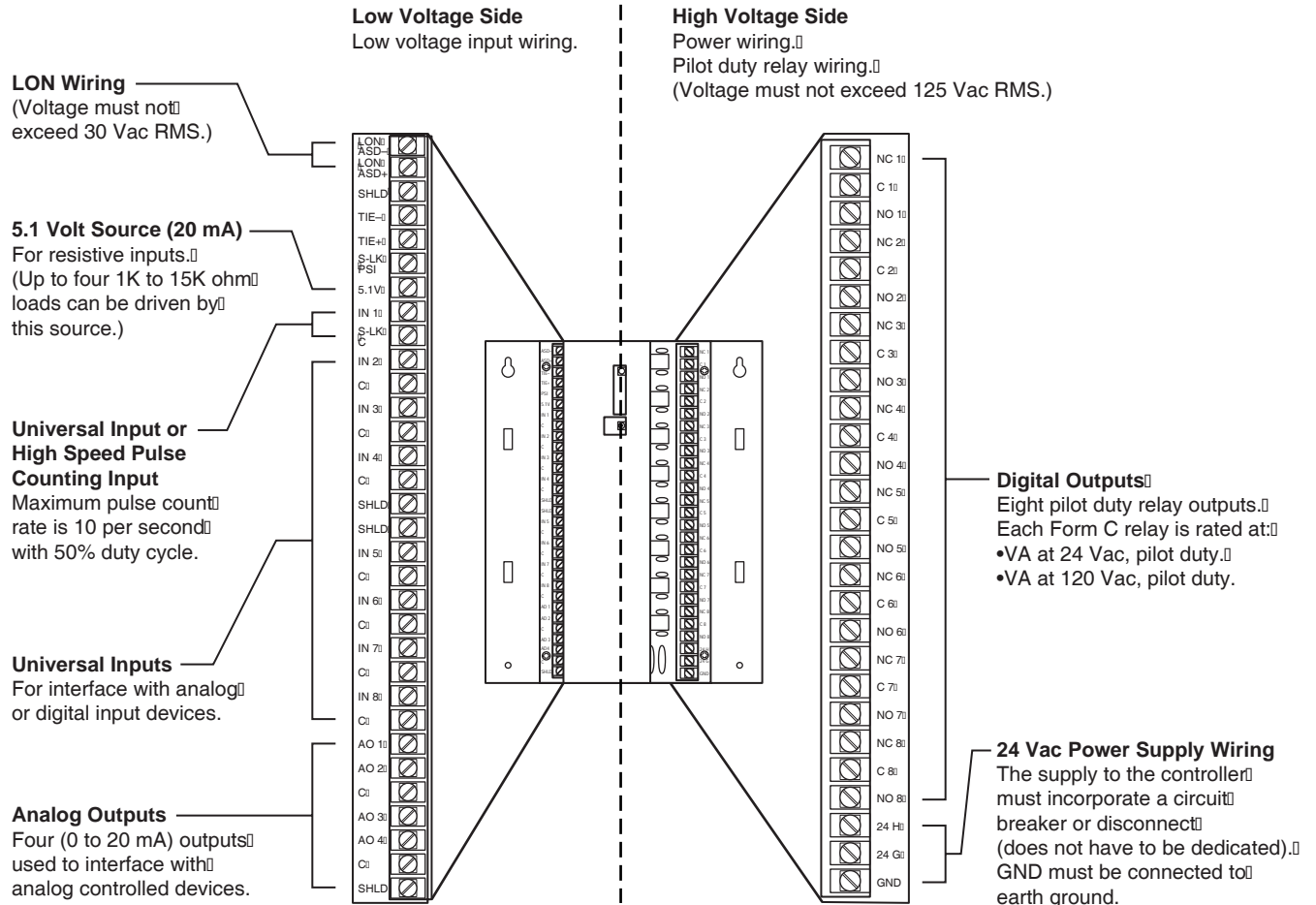

Figure-3 Terminal Connections.

**Caution:**

- Do not install the low voltage input/output wiring (UI/AO) in the same conduit with power or DO wiring with a potential greater than 30 Vac rms.
- Use shielded cable if the low voltage input/output wiring (UI/AO) is installed in the same conduit with power or DO wiring with a potential less than 30 Vac rms.
- Do not use the inside of the sensor enclosure or the wiring compartments of the sLON-7 as a junction box for other control circuits.

Although not required, shielded cable may be used for AI, DI, and AO wiring. Fold the foil shield back over the cable jacket and compress it at the point of entry or exit of each controller. Use a sheathed cable connector in the knockout at the point of entry or exit.

After the entire system has been installed and wired, verify wiring with the use of a DVM to insure against wiring errors, overvoltage, or short circuits.

**sLON-7 Printed Circuit Board Installation**

Mount the controller and complete wiring before installing the printed circuit board.

1. Verify power is OFF.
2. Follow the Static Precautions.
3. Remove enclosure cover.

**Caution:** Do not pull or push on the circuit board components when installing or removing the printed circuit board. Doing so may result in damage to the circuit board assembly.

4. Remove and discard protected shipping tape from card slot.
5. Slide printed circuit board into place (Figure-4 ).

6. Replace enclosure cover.

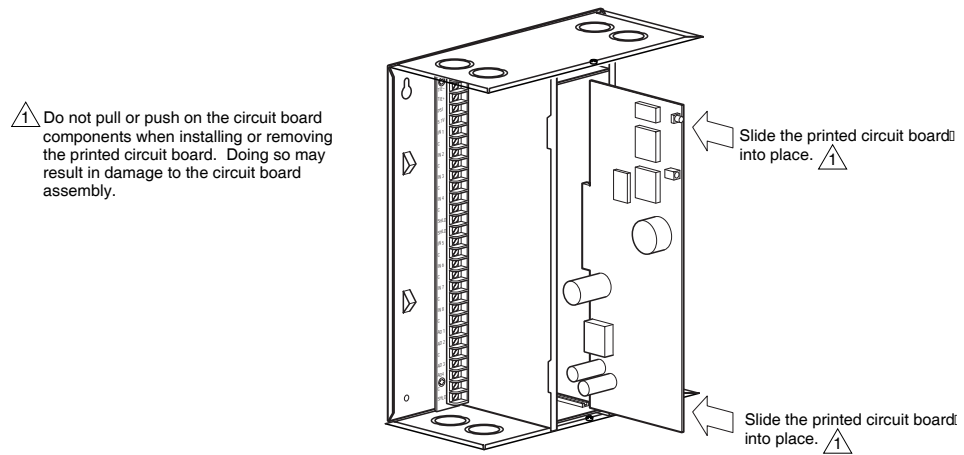

Figure-4 Printed Circuit Board Installation.

### Communications Wiring

**Caution:**

- Communication wire pairs must be dedicated to S-LK and LONWORKS network (LON) communications. They cannot be part of an active, bundled telephone trunk.
- Shielded cable is not required for S-LK or LON wiring.
- If the cable is installed in areas of high RFI/EMI, the cable must be in conduit.
- If shielded wire is used, the shield must be connected to earth ground at one end only by a 470K ohm 1/4 watt resistor. Shield must be continuous from one end of the trunk to the other.

Communications wiring includes a connection between the controller and an sLON-WTSx Sensor via the S-LK and a connection between the controller and the LONWORKS Network (LON). An optional LON connection between the controller and one sensor is also possible.

### Sensor Link (S-LK) Wiring

S-LK wiring powers and enables the sLON-WTSx sensor. The S-LK needs at least 24 gage (0.51mm), twisted pair, voice grade telephone wire. The capacitance between conductors cannot be more than 32 pF per foot (0.3m). If shielded cable is used, the capacitance between any one conductor and the others, connected to the shield, cannot be more than 60 pF per foot (0.3m). Maximum wire length is 200 ft. (61m).

**Note:**

- Controller supports one sLON-WTS sensor (sLON-WTSx).
- S-LK wiring is polarity insensitive.
- If conduit is used between a sensor and a controller, the LONWORKS network and S-LK wiring can be in the same conduit.
- S-LK wiring (*not* LON wiring) can be in the same conduit with UI, AO, and DI Wiring.

### LONWORKS Network (LON) Wiring

A Category 4, twisted-pair (two conductors) cable may be used for LON connection between controllers and between a controller and an sLON-WTSx sensor. LON wiring is polarity insensitive.

**Caution:** Do not mix with UI, AO, DI or DO types of wiring. If conduit is used between an sLON-WTS sensor and a controller, LON wiring and S-LK wiring can be in the same conduit.

sLON-7 controllers use LONWORKS Free Topology Transceiver (FTT-10) and support polarity insensitive bus (daisy-chain) and free (all combinations of star, tee, and loop) wiring topologies. A maximum of 62 nodes can be connected per segment.

## Checkout

### Stand-alone Controller

1. Verify controlled devices are not powered or are in a controlled manual condition.
2. Apply power to sLON-7 controller.
3. Check LED operation using Table-1.

**Table-1 LED Indications.**

LED	Operation	Status
Green	ON	Normally ON indicating controller is powered and not actively transmitting data on the LON.
	Flashes OFF	Flashes OFF while actively transmitting data on the LON.
Amber	OFF	Normally OFF unless actively receiving data from the LON.
	Flashes ON	Flashes ON while actively receiving data from the LON.
Red	OFF	(Neuron - normal communications) Indicates the Neuron is operating properly allowing normal communications to and from the HVAC application.
	OFF	(Neuron - Off line) Neuron responds to network management messages only. In this state, communication to and from the HVAC application is not possible. To Correct, place the Neuron on-line by downloading an application using WPT Software Tool or configure using a third party management tool.
	Blinking	The service LED blinks at 0.5 Hz rate (1 second ON, 1 second OFF) to indicate that the Neuron is unconfigured (i.e. communications parameters not loaded). Corrective action: Configure the Neuron by downloading an application using the WPT Software Tool or configure the neuron using a third party management tool.
	ON	Indicates Neuron is not operating properly. Replace controller.
Heartbeat (Green LED)	Blinking	(Normal operation) The heartbeat LED blinks at 0.5 second ON, 0.5 second OFF to indicate controller is operating properly.
	Wink Mode	Wink mode provides a visual means for identifying the controller using WPT Software Tool or third party management tool. During wink, the LED blinks at two seconds ON, half second OFF - repeated five times.
	Diagnostic Blink	(RAM/ROM Failure) The heartbeat LED repeats a pattern of 2 quick flashes followed by a pause. To correct, turn power OFF then ON. Replace controller if necessary.
	Diagnostic Blink	(ROM Failure) The heartbeat LED repeats a pattern of three quick flashes followed by a pause. To correct, turn power OFF then ON. Replace controller if necessary.
	Diagnostic Blink	(RAM Failure) The heartbeat LED repeats a pattern of four quick flashes followed by a pause. To correct, turn power OFF then ON. Replace controller if necessary.
	OFF	Indicates controller is not operating properly. Check power. Replace controller if necessary.

4. Power down sLON-7 controller if the programming will be done later, or program using WPT Software Tool.

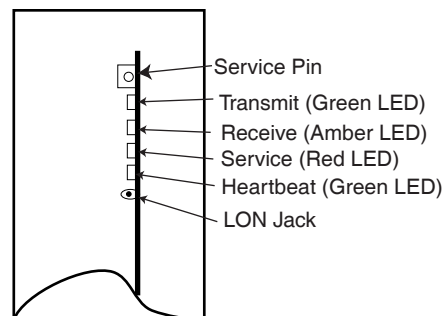

Figure-5 LED Indicators.

## Service

Components within the sLON-7 are not field repairable. The printed circuit board may be replaced, if necessary. (Follow the procedure described earlier in the Printed Circuit Board Installation section.)

© Copyright 2005 Solidyne Corp. All rights reserved.  
No part of this document may be photocopied or reproduced by any means,  
or translated to another language without prior written consent of Solidyne  
Corporation.

All specifications are nominal and may change as design improvements are  
introduced. Solidyne shall not be liable for damages resulting from  
misapplication or misuse of its products.

Echelon, LON, Neuron, 3150, LONMARK and LONWORKS are trademarks of Echelon  
Corporation registered in the United States and other countries.